

SINGER
312T141

ALL PARTS PROD CODE 610
DROP THE A IN FRONT OF NUMBER

G. Koehler

SINGER

INDUSTRIAL SEWING MACHINE

312

T141

From the library of: Diamond Needle Corp

312T141 MACHINE

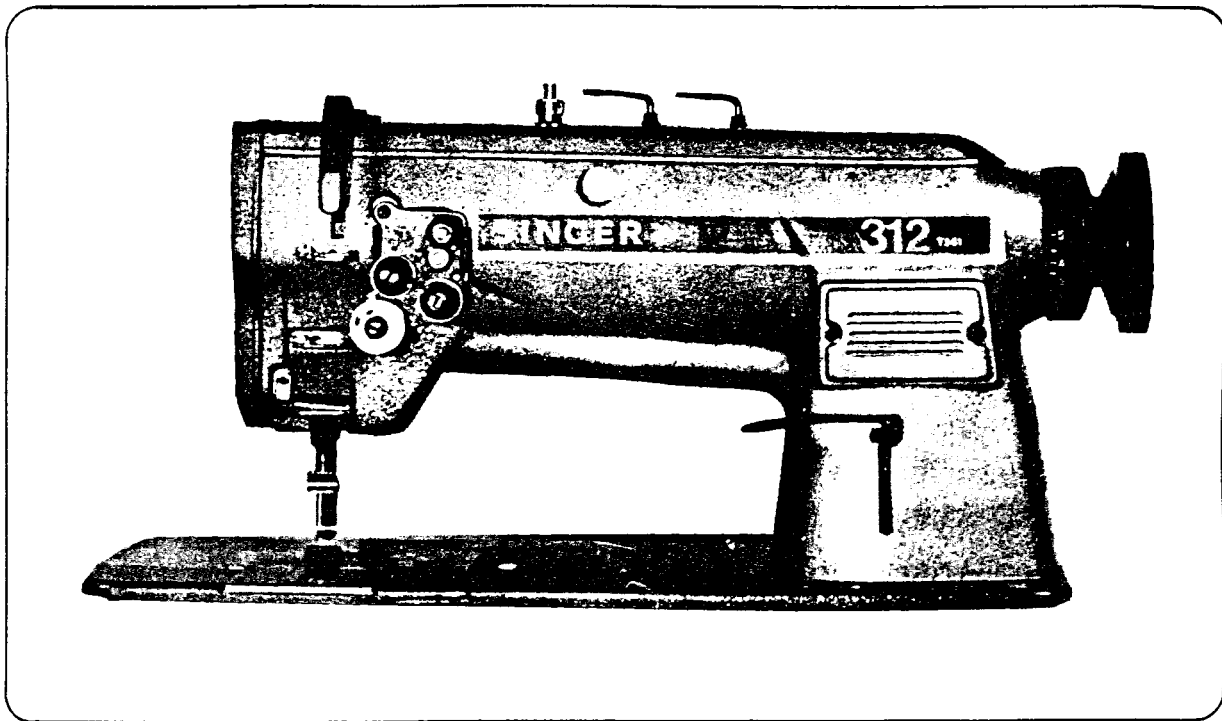

ILLUSTRATED PARTS LIST

1. TOTAL ASSY,

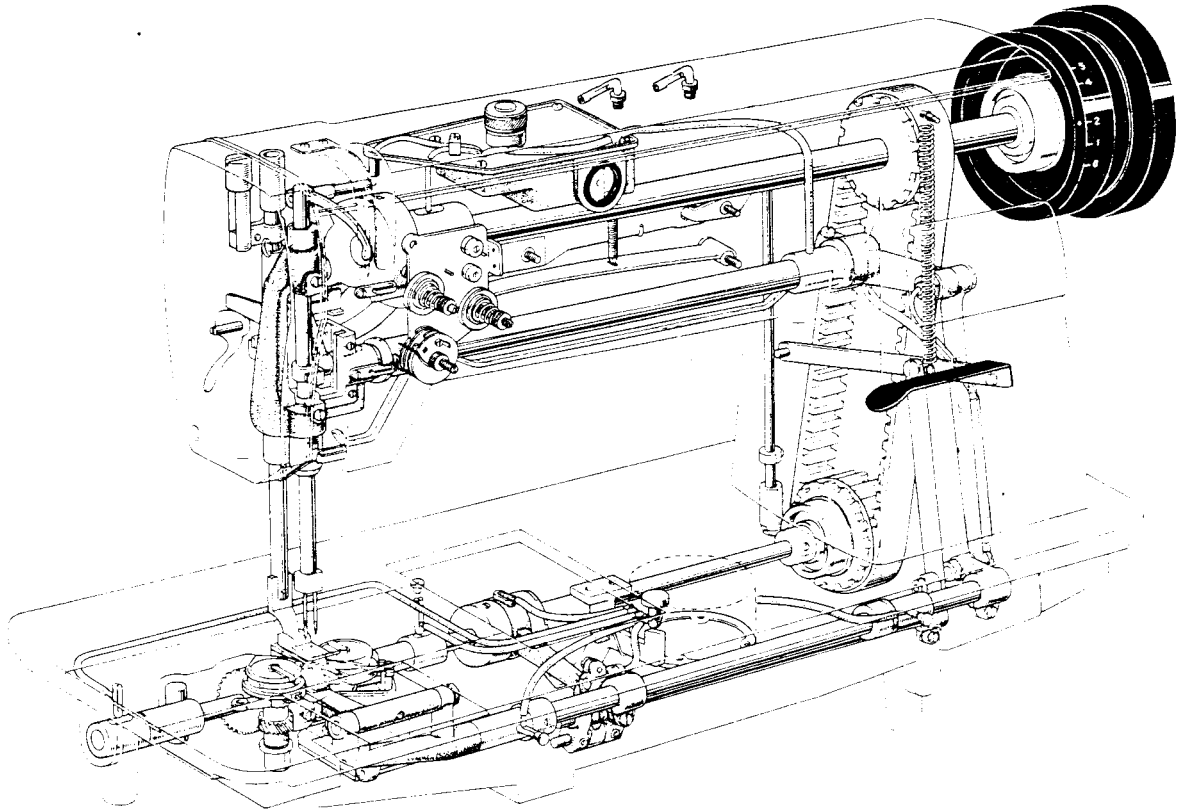

INDEX

	Page
1. Total assy	1
2. Arm and bed	2
3. Upper shaft mechanism	4
4. Presser foot mechanism	5
5. Thread take-up mechanism	6
6. Lower shaft mechanism	7
7. Lower feed mechanism	8
8. Hook mechanism	9
9. Lubrication mechanism	10
10. Reverse lever mechanism	12
11. Accessories (Accessories box)	13

2. ARM AND BED

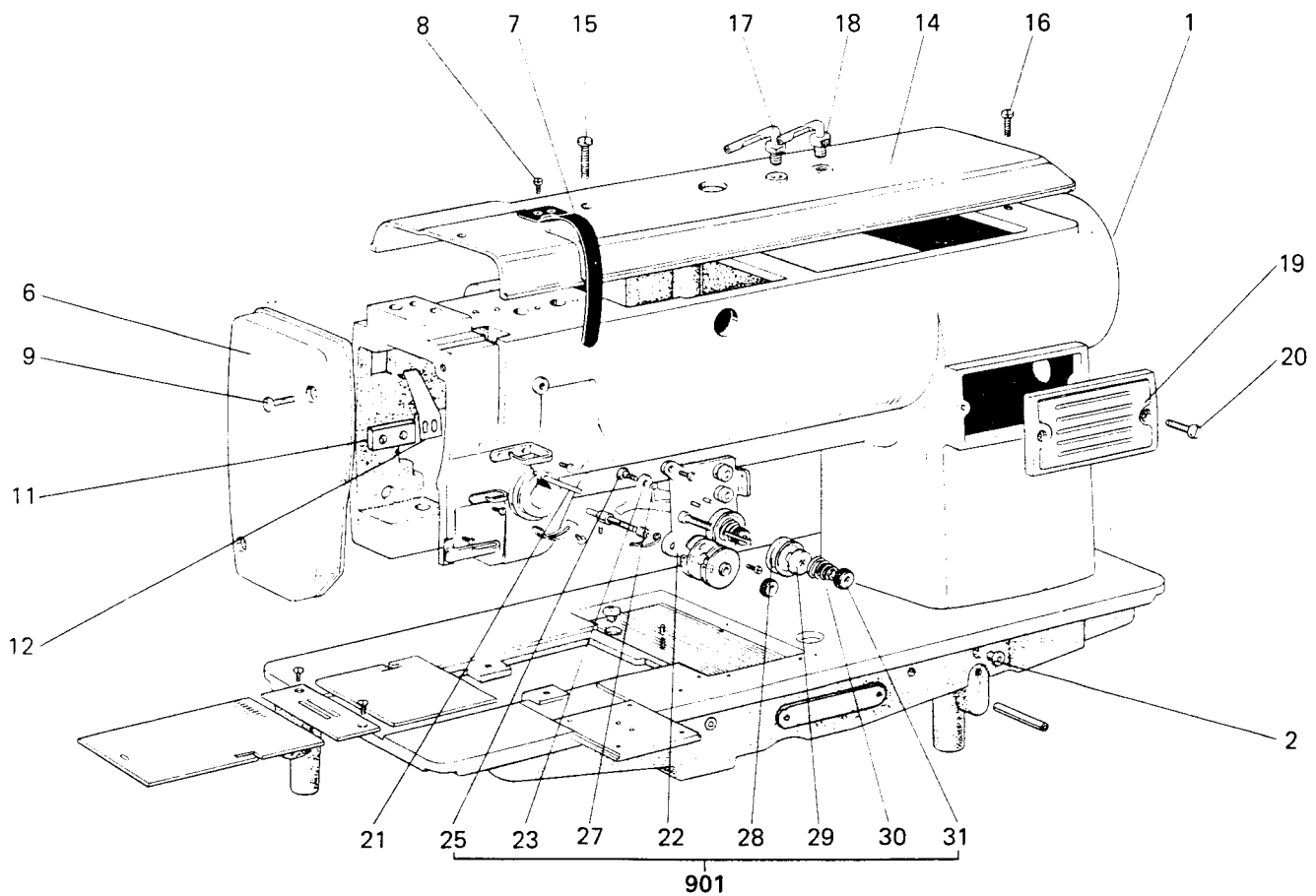

Ref. No.	Part No.	Description	Ref. No.	Part No.	Description
1	A610-E001	Arm and bed	27	A610-G027	Reverse spring
2	A610-G002	Cover (3)	28	A610-G028	Tension disc (4)
6	A610-G006	Face plate	29	A610-G029	Disc presser (2)
7	A610-G007	Thread take-up lever guard	30	A610-G030	Tension spring #3 (2)
8	A610-G008	Screw	31	A610-G031	Tension nut (3)
9	A610-S086	Face plate set screw (2)	901	A610-G901	Thread tension regulator Assy.
11	A610-G011	Washer			
12	A610-G012	Oil rejector			
14	A610-G014	Top cover			
15	A610-G015	Screw for top cover			
16	A610-S080	Screw for top cover			
17	A610-G017	Thread guide for top cover (2)			
18	A610-N007	Thread guide nut (2)			
19	A610-G019	Front cover			
20	A610-S091	Front cover screw (2)			
21	A610-G021	Thread releasing pin (large)			
22	A610-G022	Thread regulator plate			
23	A610-G023	Thread regulator plate (2)			
25	A610-S072	Screw (2)			

2. ARM AND BED

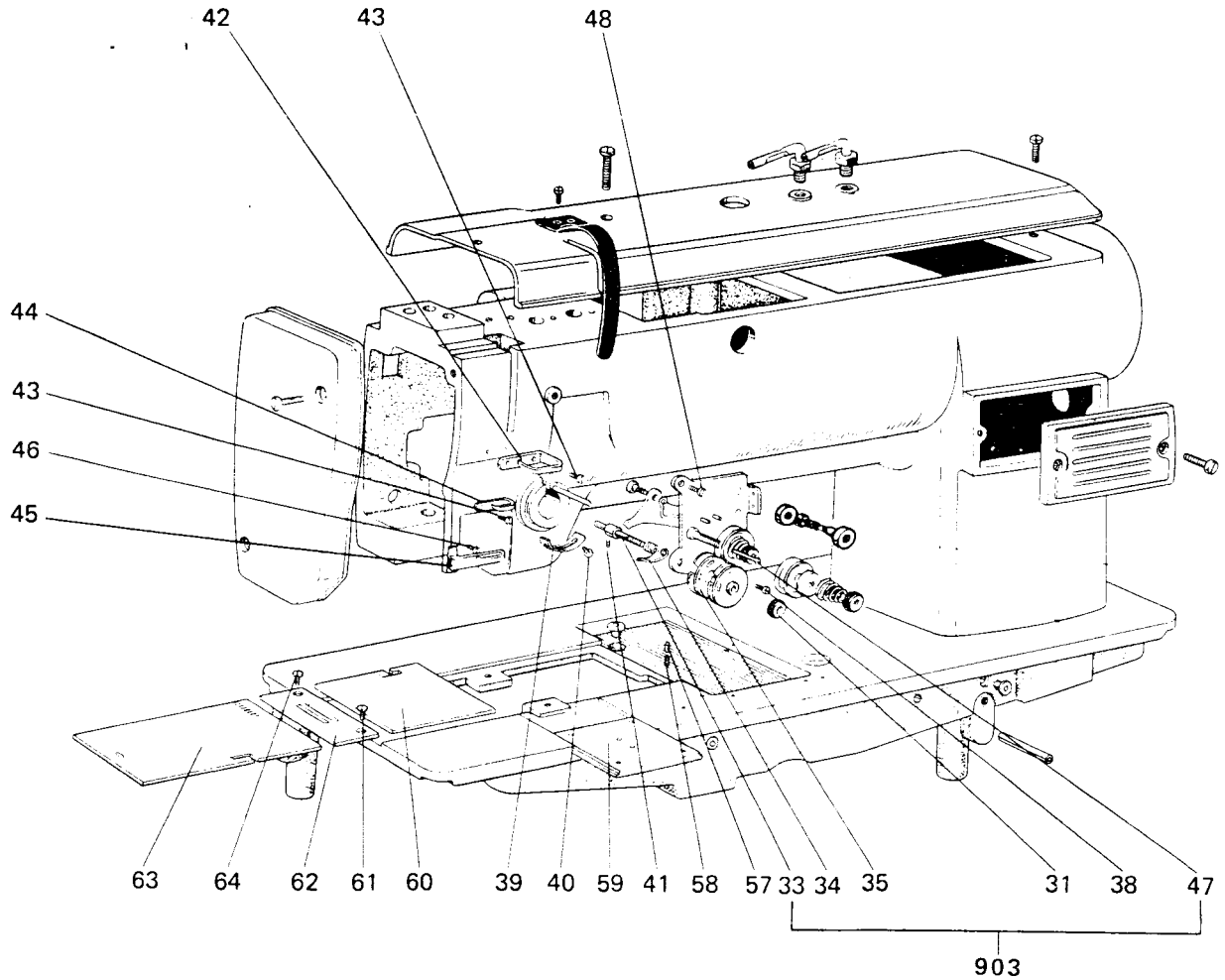

Ref. No.	Part No.	Description	Ref. No.	Part No.	Description
33	A610-G033	Tension stud	61	A610-S090	Screw
34	A610-G034	Take-up spring	62	A610-GL14	Throat plate (Needle gauge 3/16)
35	A610-G035	Thread controller disc Assy (2)		A610-GL19	Throat plate (Needle gauge 1/4)
38	A610-S120	Screw	63	A610-G063	Slide plate (left)
903	A610-G901	Thread tension regulator Assy.	64	A610-S119	Screw
39	A610-G039	Tension spring stopper			
40	A610-S072	Screw			
41	A610-G041	Screw (2)			
42	A610-G042	Thread guide (upper)			
43	A610-S074	Screw (2)			
44	A610-G044	Thread guide (center)			
45	A610-G045	Thread guide (lower)			
46	A610-S074	Screw			
47	A610-G047	Thread releasing pin (small) (2)			
48	A610-S089	Screw			
908		Thread guide disc Assy. (2)			
57	A610-G057	Pin			
58	A610-G058	Spring			
59	A610-G059	Slide plate (front)			
60	A610-G060	Slide plate (right)			

3. UPPER SHAFT MECHANISM

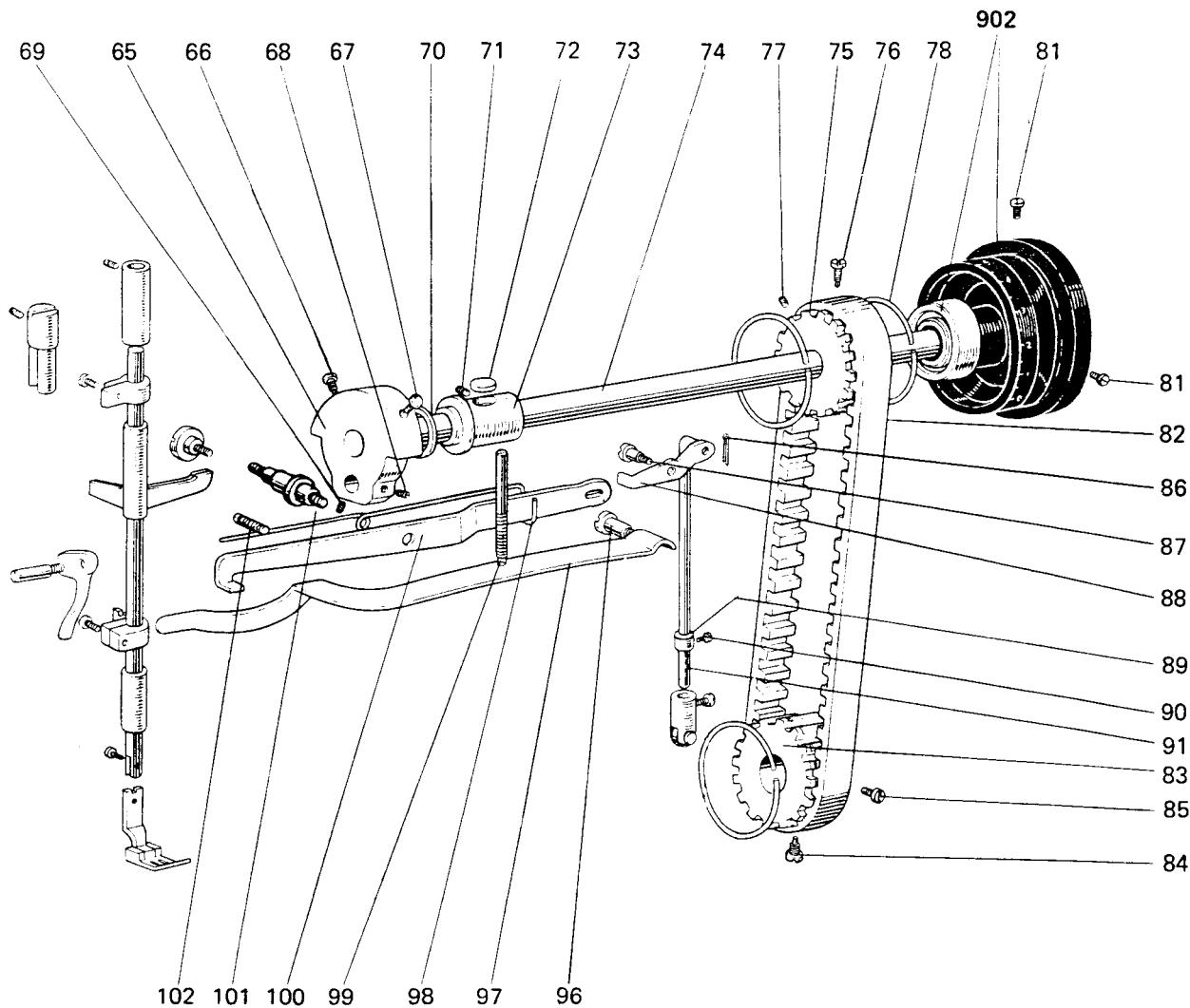

Ref. No.	Part No.	Description	Ref. No.	Part No.	Description
65	A610-G065	Needle bar crank	86	A610-G086	Cotter pin
66	A610-S122	Position screw	87	A610-S127	Screw
67	A610-S121	Screw	88	A610-G088	Knee lifter lever #2
68	A610-S110	Set screw	89	A610-G089	Collar
69	A610-S111	Set screw	90	A610-S072	Screw
70	A610-G070	Ring	91	A610-G091	Lifting rod
71	A610-S131	Screw for arm shaft bushing			
72	A610-G072	Felt	96	A610-S125	Screw
73	A610-G073	Arm shaft bushing	97	A610-G097	Presser spring
74	A610-G074	Arm shaft	98	A610-G098	Lifting lever spring
75	A610-G075	Belt pulley (upper)	99	A610-G099	Spring regulating screw
76	A610-S104	Screw	100	A610-G100	Lifting lever
77	A610-S109	Screw	101	A610-G101	Lifting lever hinge screw
78	A610-G078	Spring flange (3)	102	A610-G102	Spring stop screw
81	A610-S108	Set screw (2)			
82	A610-G082	Timing belt			
83	A610-G083	Belt pulley (lower)			
84	A610-S115	Screw			
85	A610-S114	Screw			
902	A610-G902	Machine pulley Assy.			

5. THREAD TAKE-UP MECHANISM

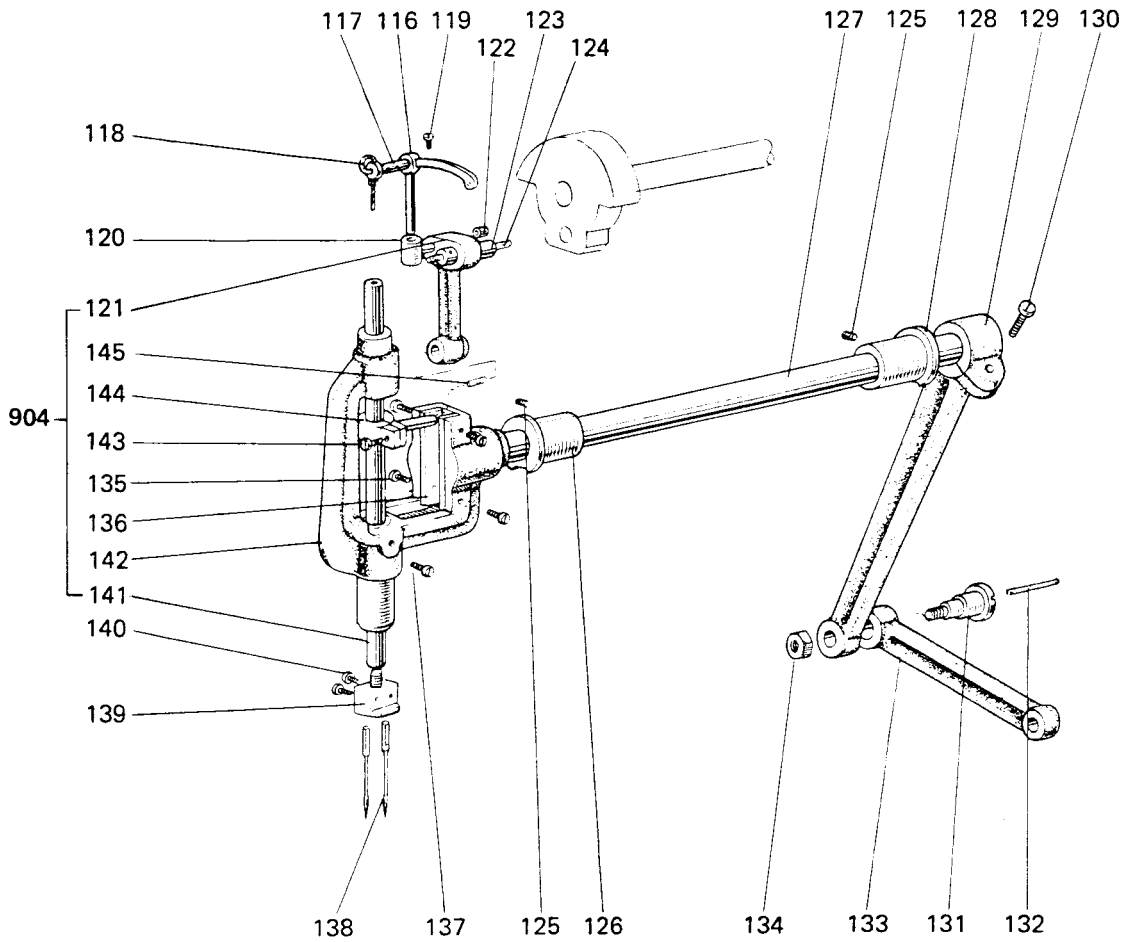

Ref. No.	Part No.	Description	Ref. No.	Part No.	Description
116	A610-G116	Thread take-up lever	134	A610-N012	Nut
117	A610-G117	Take-up lever support stud	135	A610-S123	Screw (4)
118	A610-G118	Oil wick	136	A610-G136	Spacer (2)
119	A610-S108	Screw	137	A610-S102	Screw (4)
120	A610-G120	Take-up slide block	138	A610-G138	Needle #14 (2)
121	A610-G121	Needle bar connection link	139	A610-GC19	Needle clamp (Needle gauge 3/16)
122	A610-G122	Plug (aluminium)		A610-GC14	Needle clamp (Needle gauge 1/4)
123	A610-G123	Crank pin	140	A610-S084	Set screw (2)
124	A610-G124	Felt	141	A610-G141	Needle bar
125	A610-S130	Screw (6)	142	A610-G142	Needle bar rock frame
126	A610-G126	Needle bar rock frame rock shaft bushing (left)	143	A610-S071	Screw
127	A610-G127	Needle bar rock frame rock shaft	144	A610-G144	Needle bar connecting stud
128	A610-G128	Needle bar rock frame rock shaft bushing (right)	145	A610-G145	Felt
129	A610-G129	Needle bar rock frame rock shaft crank	904	A610-G904	Needle bar rock frame Assy.
130	A610-S124	Screw (2)			
131	A610-G131	Hinge screw			
132	A610-G132	Oil wick			
133	A610-G133	Rock shaft crank link			

6. LOWER SHAFT MECHANISM

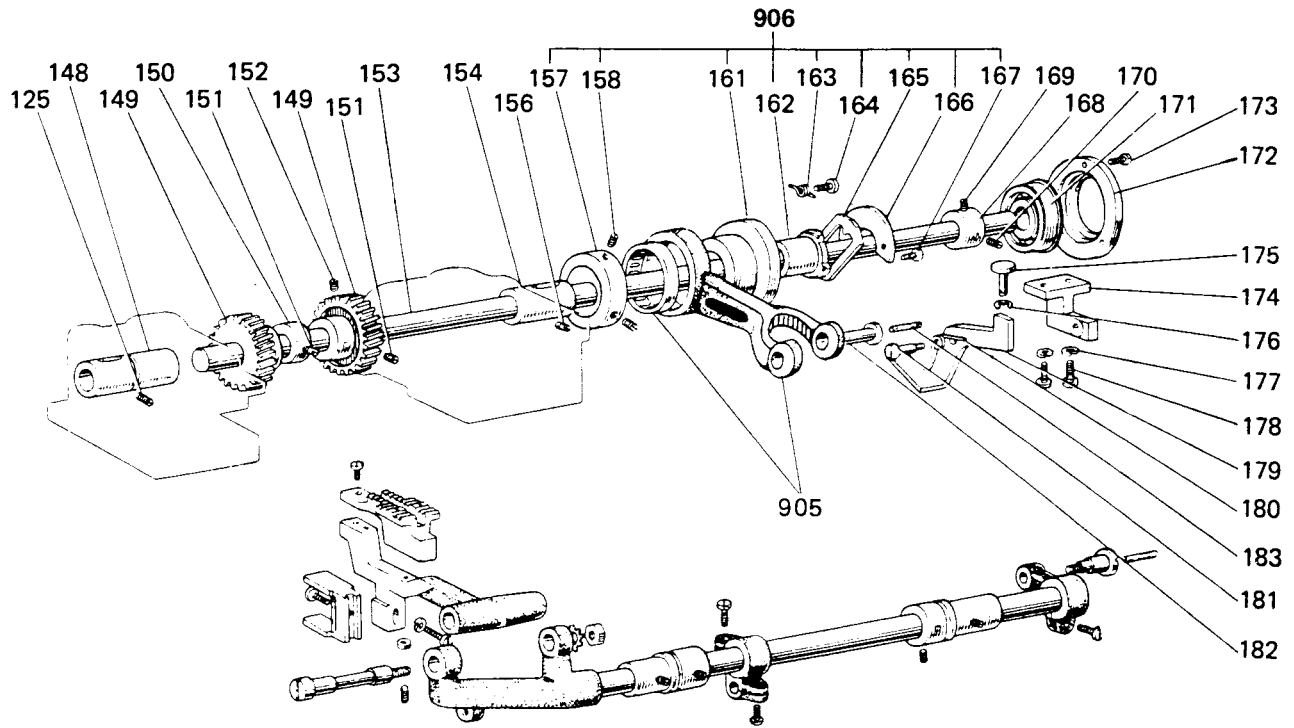

Ref. No.	Part No.	Description	Ref. No.	Part No.	Description
148	A610-G148	Hook driving shaft bushing (left)	173	A610-S074	Screw (3)
149	A610-G149	Gear (large) (2)	174	A610-G174	Lever bracket
150	A610-G150	Feed lifting cam	175	A610-G175	Push button
151	A610-S136	Screw (2)	176	A610-G176	Stop ring
152	A610-S135	Screw (8)	177	A610-G177	Spring washer (2)
153	A610-G153	Hook driving shaft	178	A610-S088	Screw (2)
154	A610-G154	Hook driving shaft bushing (right)	179	A610-G179	Push button lever
156	A610-S131	Screw (2)	180	A610-G180	Twisted spring
158	A610-S109	Screw (2)	181	A610-S087	Screw
163	A610-G163	Spring	182	A610-G182	Pin
164	A610-S075	Screw	183	A610-G183	Oil wick
165	A610-G165	Friction plate	905	A610-E905	Feed connecting rod Assy
166	A610-G166	Cover plate			
167	A610-S072	Screw (2)			
168	A610-G168	Needle bar connecting stud			
169	A610-S135	Screw			
170	A610-S136	Screw			
171	A610-G171	Ball bearing (lower shaft)			
906	A610-G906	Feed regulator Assy			
172	A610-G172	Bearing holder			

From the library of: Diamond Needle Corp

7. LOWER FEED MECHANISM

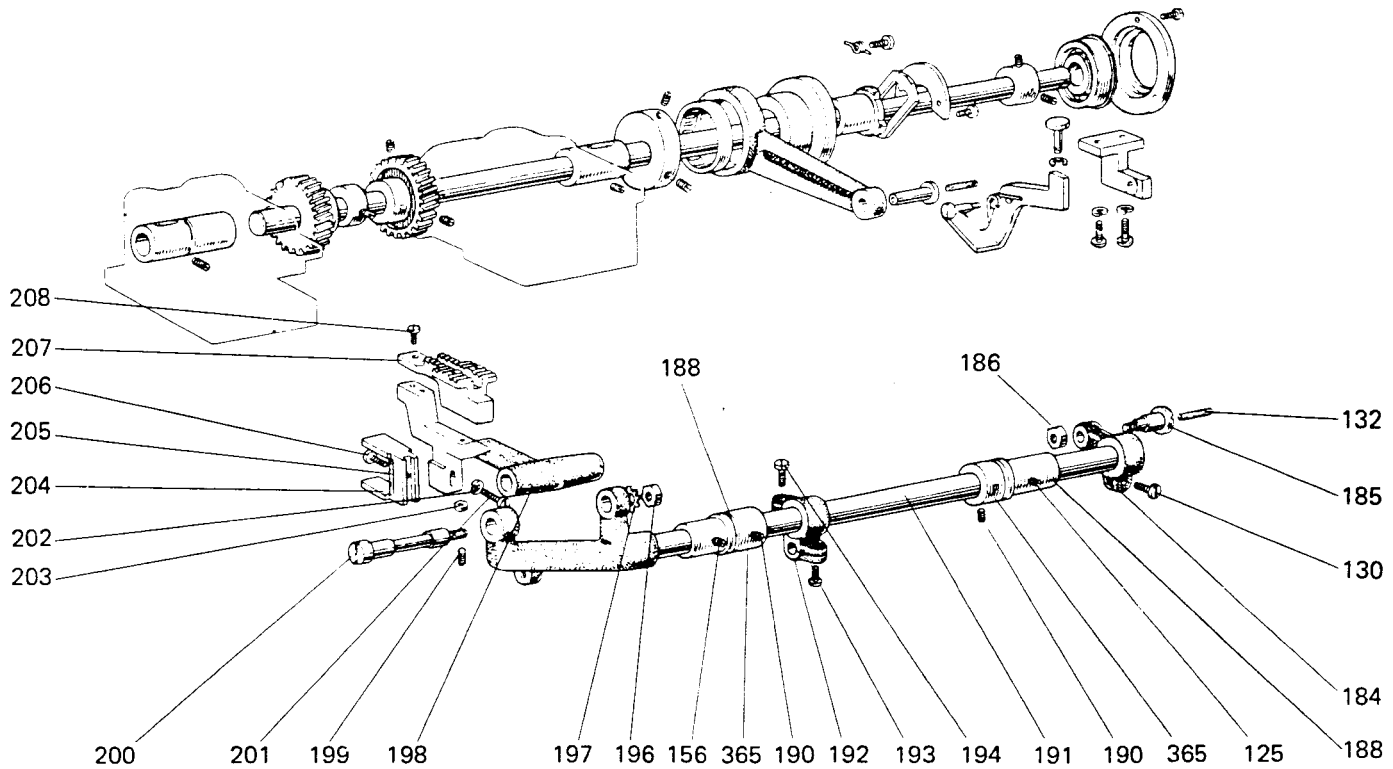

Ref. No.	Part No.	Description	Ref. No.	Part No.	Description
184	A610-G184	Feed lifting crank (right)	207	A610-GD19	Feed dog (Needle gauge 3/16)
185	A610-G131	Screw		A610-GD14	Feed dog (Needle gauge 1/4)
186	A610-N012	Nut	208	A610-S117	Screw (2)
188	A610-G188	Feed driving rock shaft bushing(2)	365	A610-G365	Collar (2)
190	A610-S111	Screw (4)			
191	A610-G191	Feed driving rock shaft			
192	A610-G192	Feed driving crank (left)			
193	A610-S124	Screw			
194	A610-S097	Screw			
196	A610-N013	Nut			
197	A610-W002	Washer			
198	A610-G198	Feed bar			
199	A610-S118	Screw			
200	A610-G200	Feed bar hinge stud			
201	A610-G201	Screw			
202	A610-G202	Washer			
203	A610-N011	Nut			
204	A610-G204	Feed eccentric fork			
205	A610-G205	Felt			
206	A610-S101	Screw			

8. HOOK MECHANISM

BC TENSION SPRING 236083
 " " SCREW 200294
 " TENSION REEL SCREW 201016

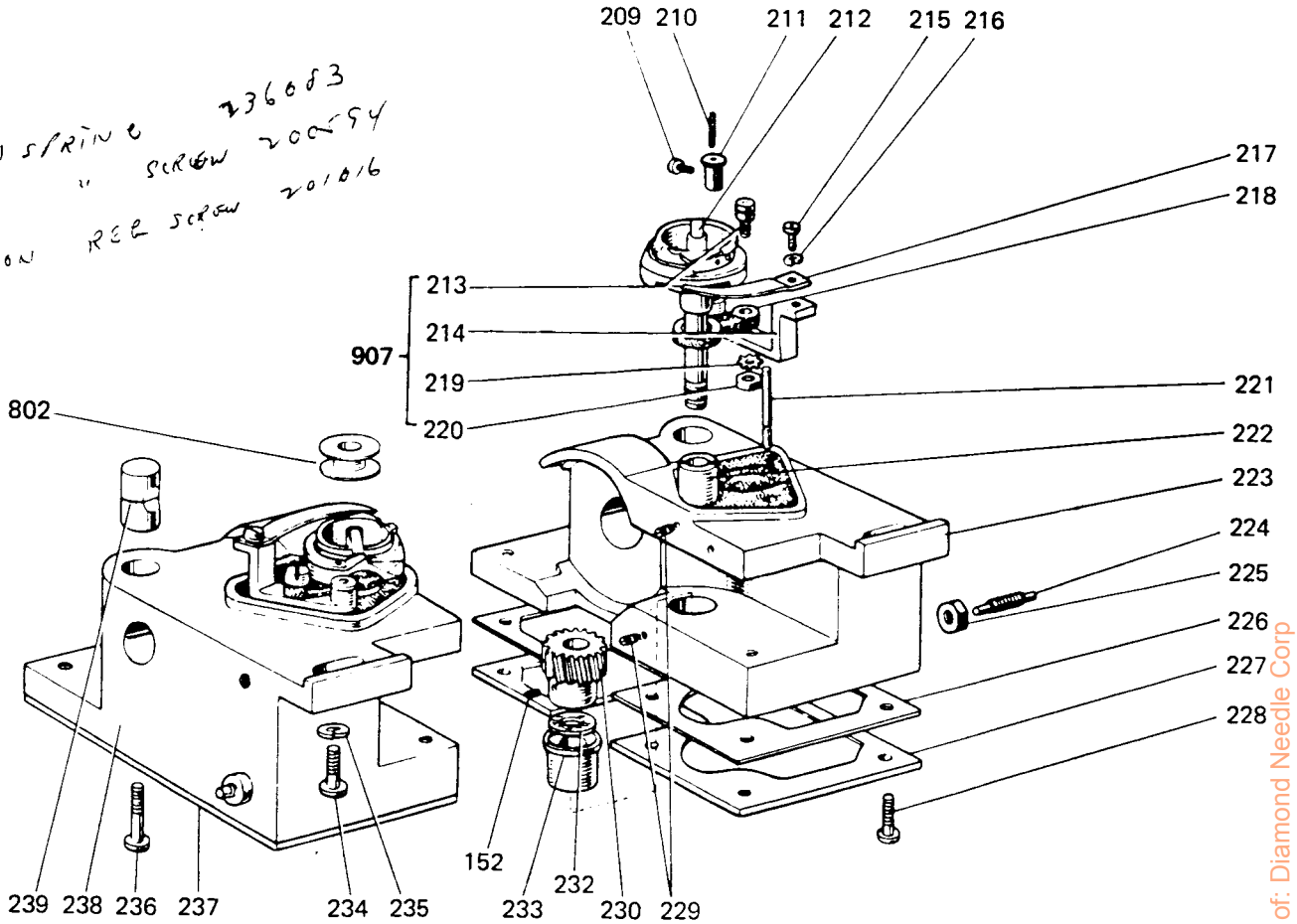

Ref. No.	Part No.	Description	Ref. No.	Part No.	Description
209	A610-S097	Screw (2)	227	A610-G227	Oil cover (hook saddle left)
210	A610-G210	Oil wick (2)	228	A610-S096	Screw (16)
211	A610-G211	Opener supporter (2)	907	A610-G907	Bobbin case opener lever Assy.
212	A610-G212	Rotating hook Assy. (2)	229	A610-S111	Screw (4)
213	A610-G213	Bobbin case opener lever pin (2)	230	A610-G230	Cam shaft gear (small) (2)
214	A610-G214	Bobbin case opener lever (2)	232	A610-G232	Washer (2)
215	A610-S072	Screw (2)	233	A610-G233	Hook driving shaft bushing (lower) (2)
216	A610-G216	Washer (2)	234	A610-S129	Screw (2)
217	A610-G217	Bobbin case opener (2)	235	A610-G235	Washer (2)
218	A610-G218	Bobbin case opener lever link (2)	236	A610-S106	Screw (2)
219	A610-W001	Toothed washer (2)	237	A610-G237	Oil cover
220	A610-N008	Nut (2)	238	A610-G238	Hook saddle (left)
221	A610-G221	Oil gauge (2)	239	A610-G239	Pinching bushing (2)
222	A610-G222	Hook driving shaft bushing (upper) (2)	802	A610-G802	Bobbin (2)
223	A610-G223	Hook saddle (right)			
224	A610-S103	Cock screw (2)			
225	A610-N008	Nut (2)			
226	A610-G226	Gasket (2)			

From the library of: Diamond Needle Corp

9. LUBRICATION MECHANISM

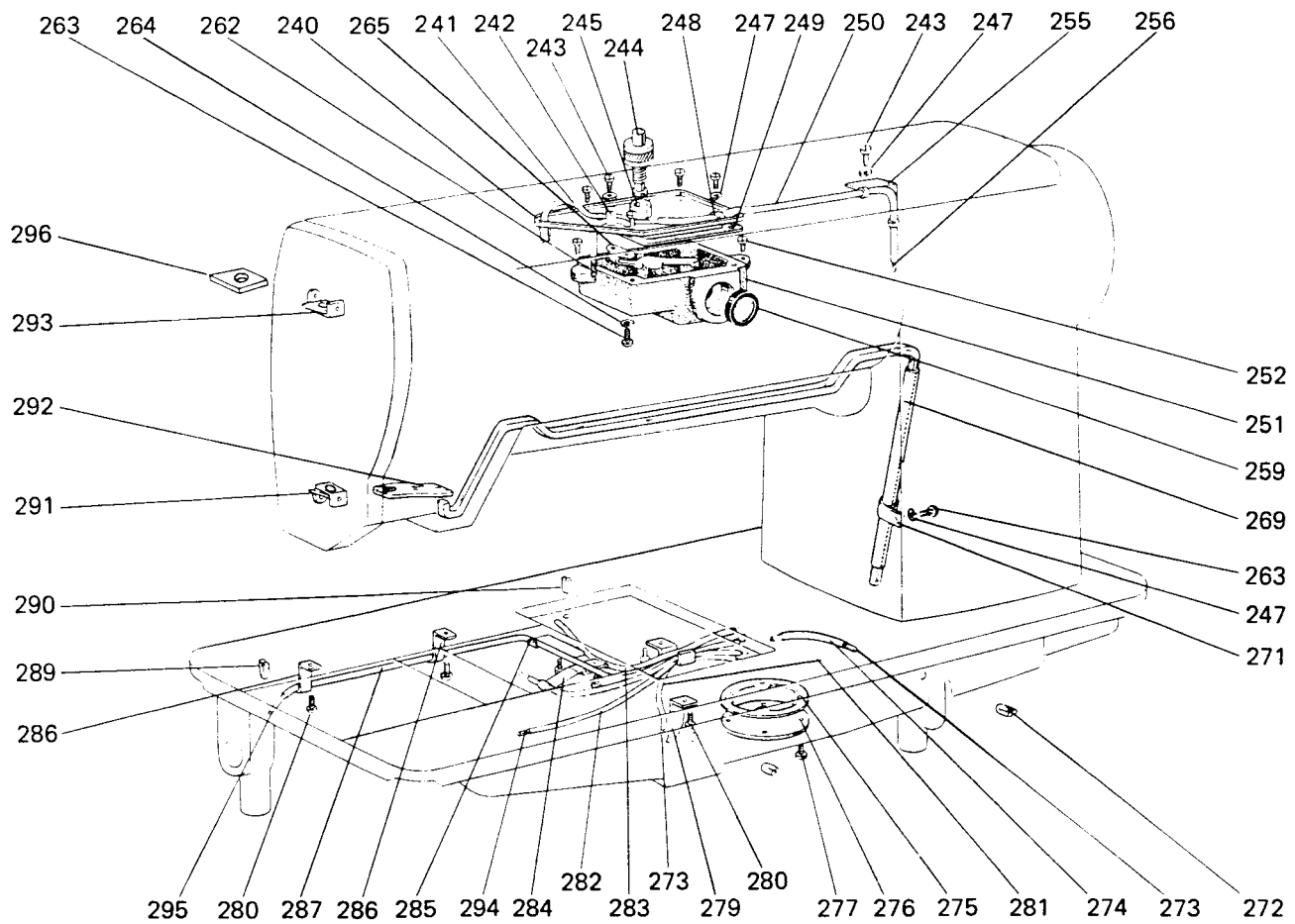

Ref. No.	Part No.	Description	Ref. No.	Part No.	Description
240	A610-G240	Drip pan cover	274	A610-G274	Vinyl tubing (2)
241	A610-G241	Oil wick	275	A610-G275	Packing (B)
242	A610-G242	Tubing holder	276	A610-G276	Cover (B)
243	A610-S074	Screw (6)	277	A610-S093	Screw (4)
244	A610-G244	Oil plunger	279	A610-G279	Tubing holder
245	A610-G245	Bushing	280	A610-S072	Screw (3)
247	A610-G247	Spring washer (8)	281	A610-G281	Vinyl tubing
248	A610-G248	Tubing holder	282	A610-G282	Vinyl tubing
249	A610-G249	Packing	283	A610-G283	Vinyl tubing
250	A610-G250	Vinyl tubing	284	A610-G284	Tubing holder
251	A610-G251	Oil reservoir	285	A610-G285	Tubing holder
252	A610-S071	Screw (2)	286	A610-G286	Tubing holder (2)
255	A610-G255	Tubing holder	287	A610-G287	Vinyl tubing
256	A610-G256	Oil wick	289	A610-G289	Oil wick
259	A610-G259	Oil flow indicator	290	A610-G290	Oil wick
262	A610-G262	Felt	291	A610-G291	Felt holder #2
263	A610-S102	Screw (2)	292	A610-G292	Felt (Needle bar rock frame)
264	A610-G264	Spring washer (2)	293	A610-G293	Felt holder #1
265	A610-G265	Tubing holder	294	A610-G294	Oil wick (2)
269	A610-G269	Vinyl tubing	295	A610-G295	Oil wick
271	A610-G271	Tubing holder			
272	A610-G272	Oil wick (2)			
273	A610-G273	Oil wick (2)			

9. LUBRICATION MECHANISM

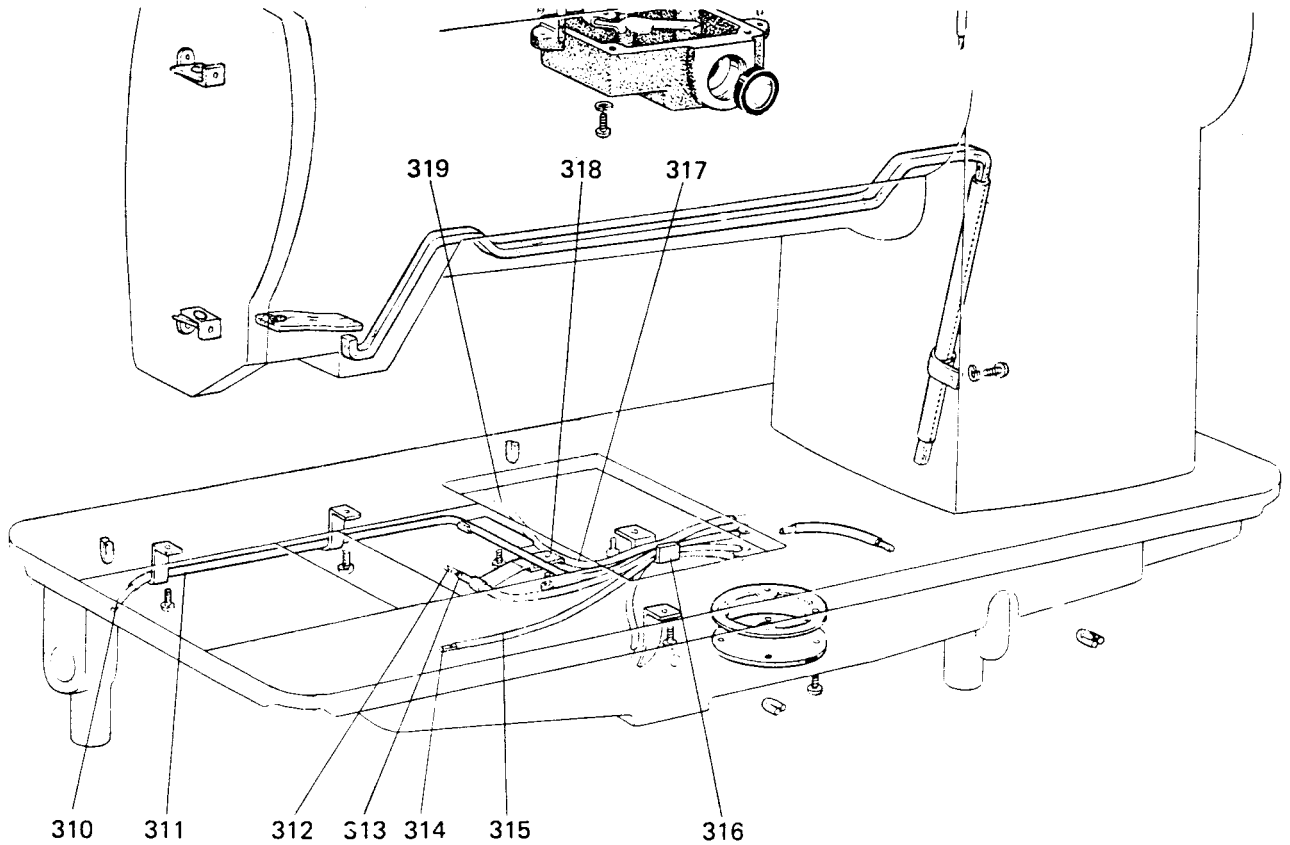

Ref. No.	Part No.	Description	Ref. No.	Part No.	Description
310	A610-G310	Oil wick			
311	A610-G311	Vinyl tubing			
312	A610-G312	Oil wick			
313	A610-G313	Vinyl tubing			
314	A610-G314	Oil wick			
315	A610-G315	Vinyl tubing			
316	A610-G316	Tubing holder			
317	A610-G317	Vinyl tubing			
318	A610-G318	Tubing holder (2)			
319	A610-G319	Oil wick			

From the library of: Diamond Needle Corp

10. REVERSE LEVER MECHANISM

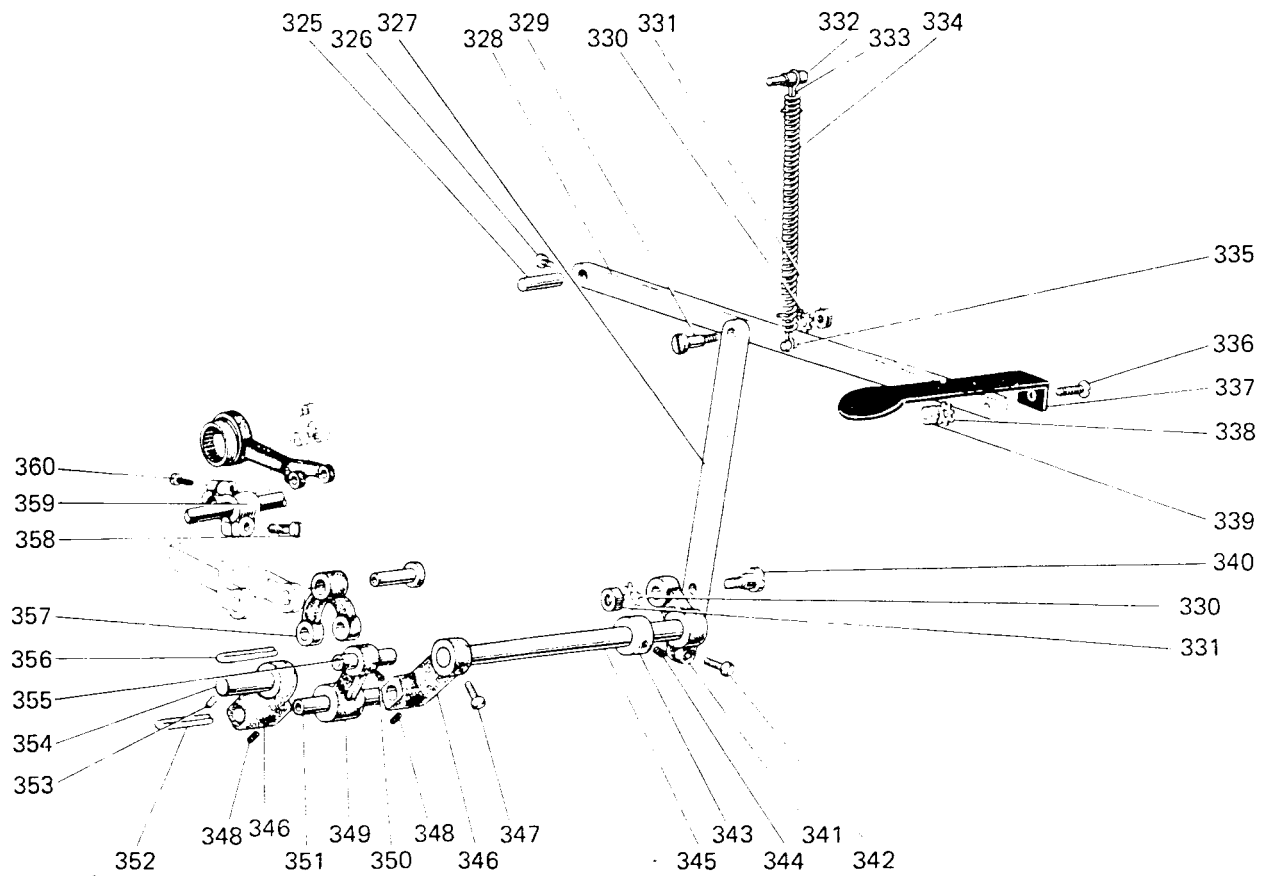

Ref. No.	Part No.	Description
325	A610-G325	Pin
326	A610-S074	Screw
327	A610-G327	Reverse lever connecting plate
328	A610-G328	Reverse stitch lever
329	A610-G329	Hinge screw
330	A610-W002	Lock washer (2)
331	A610-N009	Nut (2)
332	A610-G332	Spring guide pin
333	A610-G333	Hook for spring (2)
334	A610-G334	Coil spring
335	A610-G335	Pin for spring
336	A610-S095	Screw
337	A610-G337	Reverse stitch plate
338	A610-W001	Lock washer
339	A610-N007	Nut
340	A610-G340	Hinge screw
341	A610-G341	Reverse stitch shaft crank(right)
342	A610-G342	Screw
343	A610-G343	Collar
344	A610-S110	Screw (2)

Ref. No.	Part No.	Description
345	A610-G345	Reverse stitch shaft
346	A610-G346	Reverse stitch shaft crank (left)(2)
347	A610-S104	Screw
348	A610-S140	Screw (2)
349	A610-G349	Bell crank
350	A610-S099	Screw
351	A610-G351	Pin
352	A610-G352	Oil wick
353	A610-S130	Screw
354	A610-G354	Pin
355	A610-G355	Pin
356	A610-G356	Oil wick
357	A610-G357	Link
358	A610-S124	Screw
359	A610-G359	Feed arm (left)
360	A610-S097	Screw

From the library of: Diamond Needle Corp

11. ACCESSORIES (ACCESSORIES BOX)

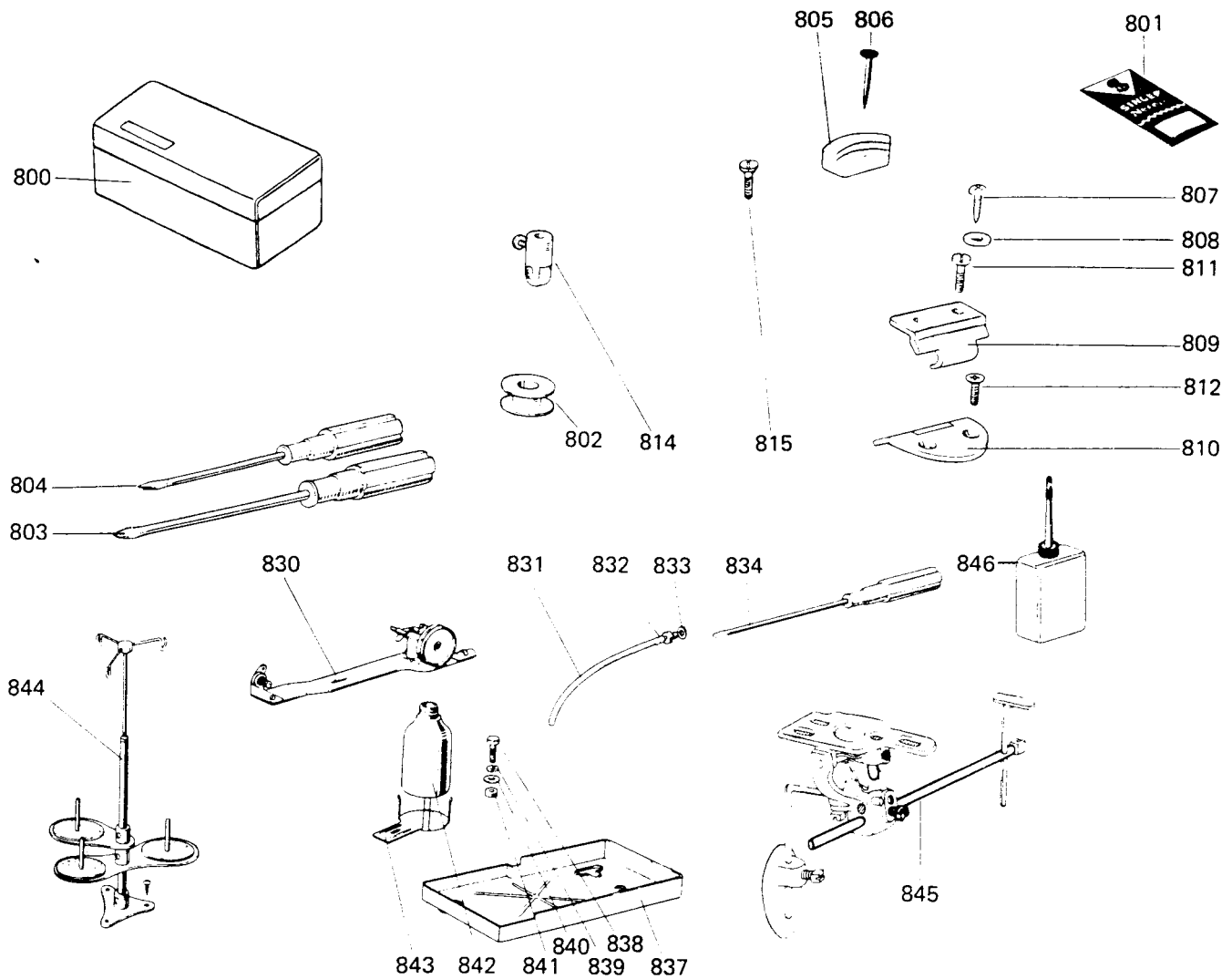

Ref. No.	Part No.	Description
800	A610-G800	Accessories box
801	A610-G801	Needle #14 (10)
802	A610-G802	Bobbin (4)
803	A610-G803	Screw driver (medium)
804	A610-G804	Screw driver (small)
805	A610-G805	Vibration preventing rubber (4)
806	A610-G806	Nail (9)
807	A610-G807	Screw (2)
808	A610-G808	Washer (2)
809	A610-G809	Hinge hook (2)
810	A610-G810	Hinge plate (2)
811	A610-G811	Screw (4)
812	A610-G812	Screw (4)
814	A610-G814	Roller (set)
815	A610-G815	Screw (2)
830	A610-G830	Bobbin winder Assy.
831	A610-G831	Vinyl tubing
832	A610-G832	Screw bushing
833	A610-G833	Packing

Ref. No.	Part No.	Description
834	A610-G834	Screw driver (large)
837	A610-G837	Oil pan
838	A610-G838	Bolt
839	A610-G839	Spring washer
840	A610-G840	Washer
841	A610-G841	Nut
842	A610-G842	Oil bottle
843	A610-G843	Oil bottle holder
844	A610-G844	Cotton stand assembly
845	A610-G845	Knee lifter (set)
846	A610-G846	Oiler (large)